

THE

General Radio EXPERIMENTER



VOLUME XXVIII No. 3

AUGUST, 1953

Copyright, 1953, General Radio Company, Cambridge, Mass., U. S. A.

ELECTRICAL MEASUREMENTS AND THEIR INDUSTRIAL APPLICATIONS

IMPROVED ACCURACY AND CONVENIENCE OF MEASUREMENTS WITH TYPE 1602-B ADMITTANCE METER IN VHF AND UHF BANDS

Also
IN THIS ISSUE
Page
 MEASUREMENTS ON
 75-OHM LINES WITH
 THE ADMITTANCE
 METER 7

● **IN ITS THREE YEARS** of field use, the TYPE 1602-A Admittance Meter¹ has proved to be a valuable and flexible instrument for the measurement of impedance and admittance at frequencies between 20 and 1500 Mc.

Its inherent utility has been greatly increased by the availability of accessories²

¹W. R. Thurston, "A Direct-Reading Impedance Measuring Instrument for the U-H-F Range," *General Radio Experimenter*, Vol. 24, No. 12, May, 1950.

²"New Coaxial Accessories — Adaptors, Line Stretcher, Component Mount, Balun, Terminations, and Insertion Unit." *General Radio Experimenter*, Vol. 27, No. 5, October, 1952.

Figure 1. Close-up of the Type 1602-B U-H-F Admittance Meter.

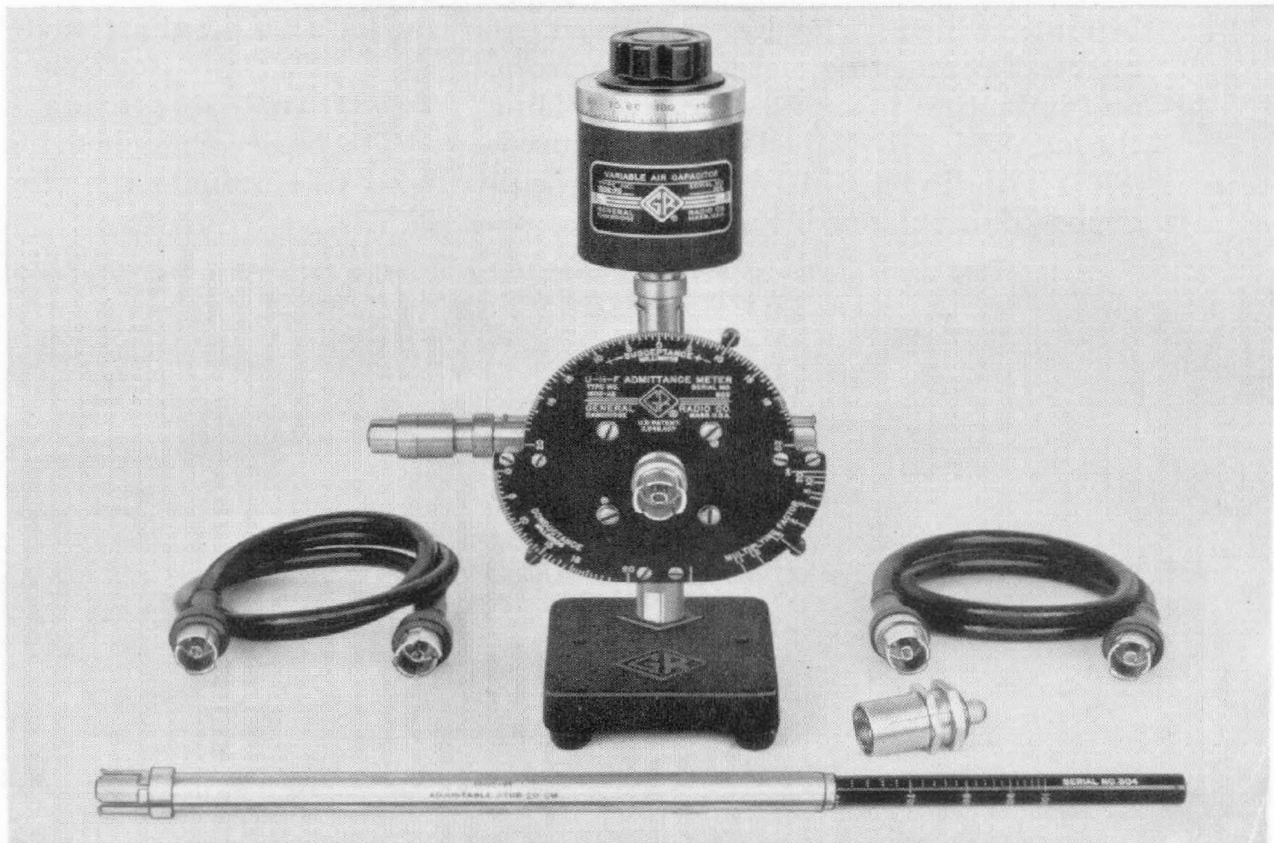
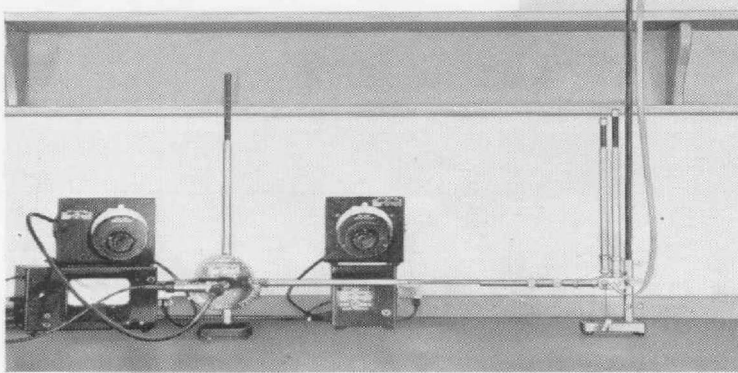

Figure 2. View of the Admittance Meter and balun as assembled for the measurement of a balanced transmission line.



to eliminate corrections and to facilitate the measurement of components, antennas, and balanced circuits. These accessories include:

(1) The TYPE 874-LK Constant-Impedance Adjustable Line, which can be adjusted to a half- or a quarter-wavelength to make the Admittance Meter direct reading in the admittance or impedance at the point where the unknown impedance is connected, without the use of Smith charts to correct for line length.

(2) The TYPE 874-M Component Mount, which provides a convenient means of connecting resistors, capacitors, and inductors to the 50-ohm coaxial line through which the impedance is measured.

(3) The TYPE 874-LB Balun, a balanced-to-unbalanced impedance trans-

former, which makes possible the measurement of impedance and VSWR of balanced 300-ohm circuits and of UHF receiving antennas.

(4) Low-reflection adaptors to most of the commonly used types of coaxial connectors, to facilitate connections to equipment fitted with connectors other than the General Radio TYPE 874. Adaptors are also available for connection to VHF and UHF television transmitting antenna systems.³

RECENT IMPROVEMENTS

Since the original model was introduced, several methods of adding to the operating convenience and accuracy have been developed. One of these improvements eliminates the effect of the junction inductance, which causes errors at the higher frequencies; another one makes possible higher accuracy when multipliers larger than unity are used; and a third extends the direct-reading, low-frequency range and also eliminates the need for the long awkward stub. The type number of the improved instrument has been changed to the TYPE 1602-B Admittance Meter to avoid confusion with previous models.

Junction Inductance

The basic principle behind the method used to eliminate the effect of junction

³To be described in a future issue of the *Experimenter*.

Figure 3. View of the Admittance Meter as set up for measurement of a resistor, showing the line stretcher and component mount.

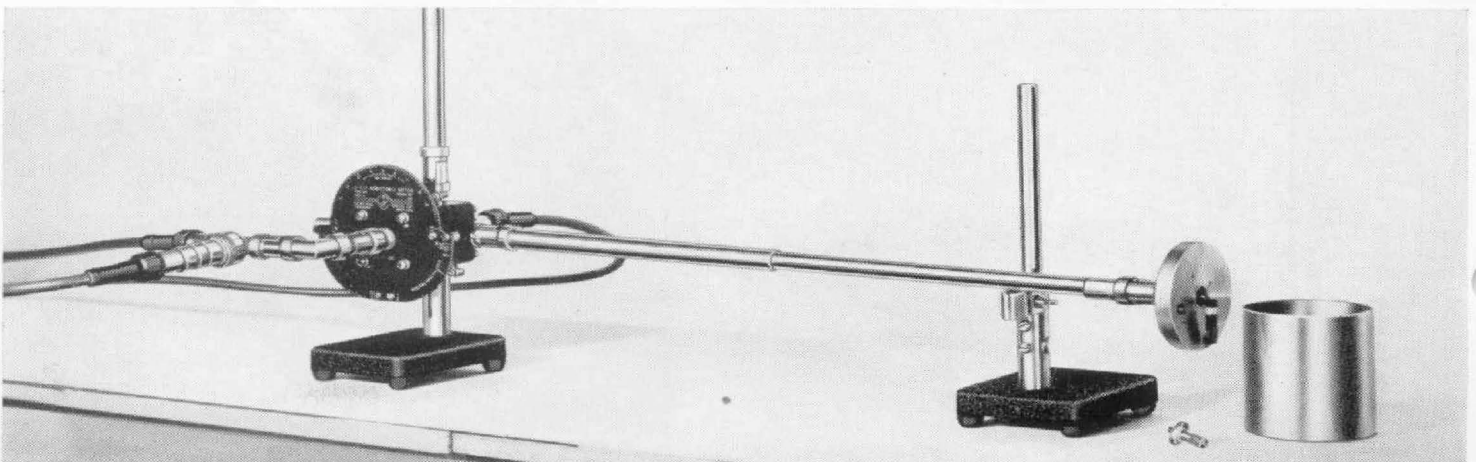



inductance is similar to that used on the TYPE 1601-A VHF Bridge to compensate for the capacitance of the unknown terminals. However, the applicability of this principle to the Admittance Meter was first realized and suggested by Messrs. G. D. Monteath and P. Knight of the British Broadcasting Corporation. The understanding of the method used to compensate for the junction inductance requires a knowledge of the principle of operation of the Admittance Meter. For convenience it will be briefly reviewed in the following paragraphs.

In the Admittance Meter, the currents flowing in three branch coaxial lines, fed from a common voltage source at a common junction point, are sampled by three independently adjustable loops, which couple to the magnetic field in each line as shown in Figure 4. One of the branch lines is connected to a conductance standard, one to a susceptance standard, and one to the unknown circuit. The outputs of the three loops are connected in parallel, and the coupling of each loop to its respective branch line is adjusted by rotating the loop until a null is obtained. At a null the settings of

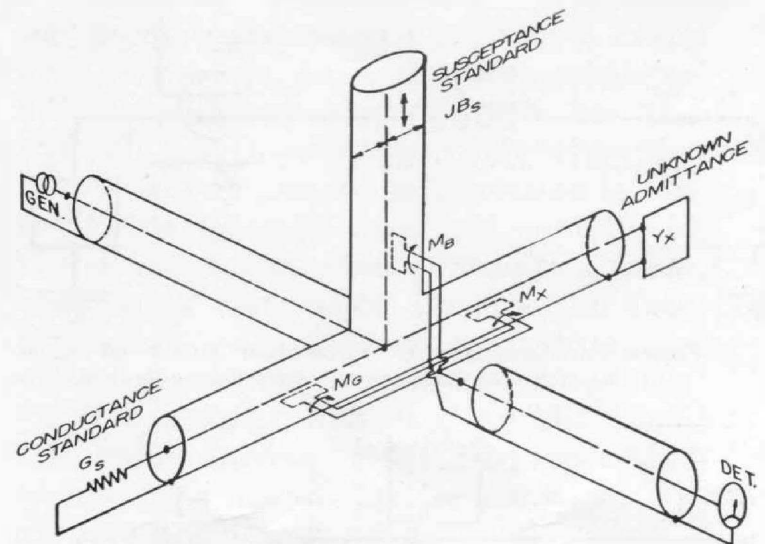
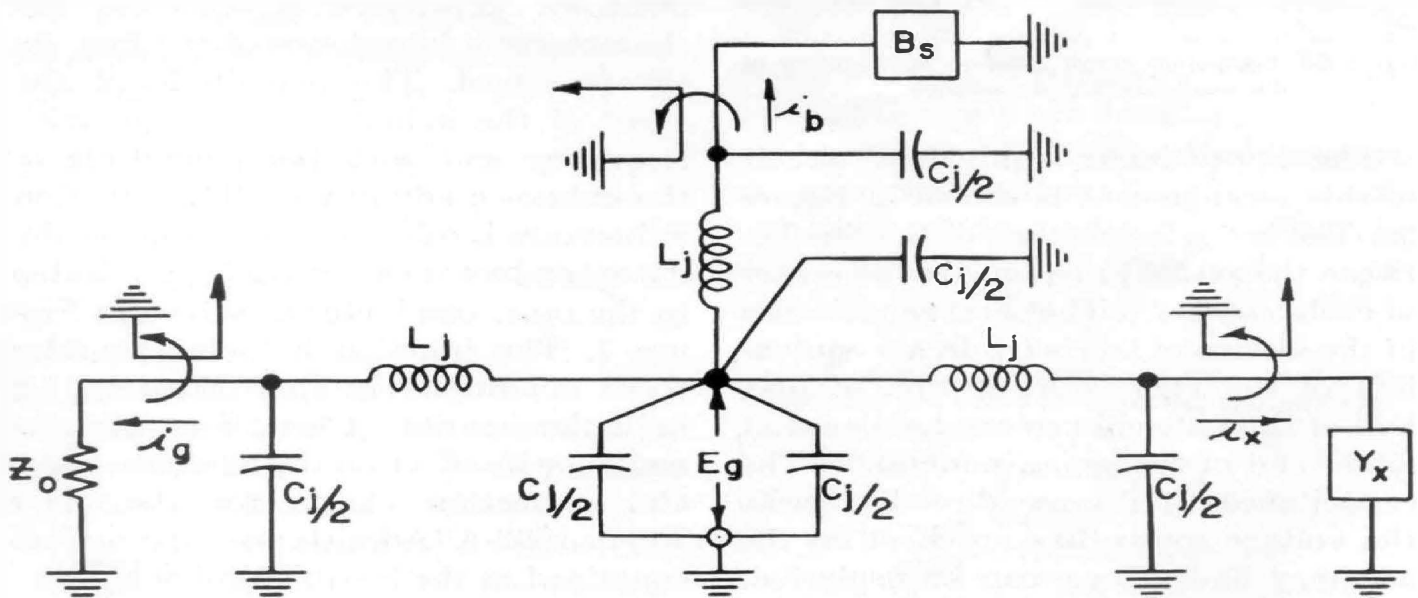

Figure 4. Schematic diagram of the Admittance Meter, showing the arrangement of coupling loop.

the loops are direct indications of the magnitudes of the conductance, the susceptance, and a multiplying factor.

The basic principle of operation assumes that the voltage at a point under the center of the coupling loop on each branch line is the same. However, in the practical case, the loops must be located at least a short distance from the actual common junction point and, hence, a short length of line exists between the common junction point and the center of each pickup loop as shown in Figure 4.

Figure 5a. Equivalent circuit of the junction.



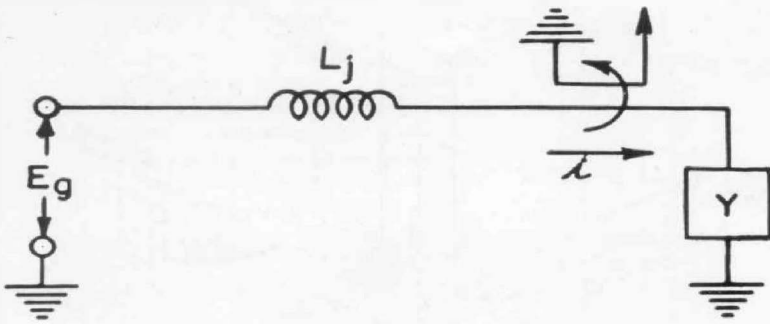

Figure 5b. Approximate equivalent circuit of each branch with junction capacitance neglected.

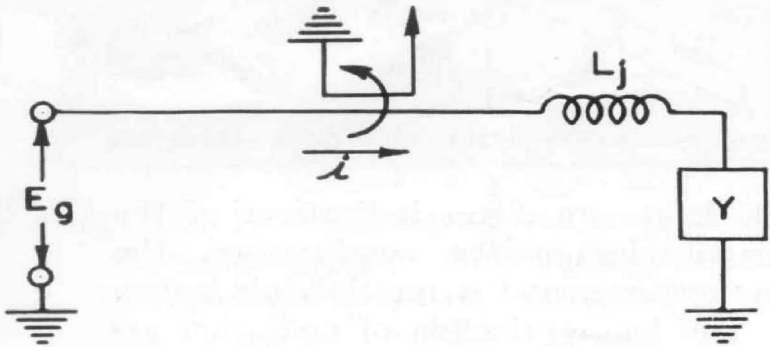

Figure 5c. Revised circuit of Figure 5b, with junction inductance shifted to the load side of the coupling loop.

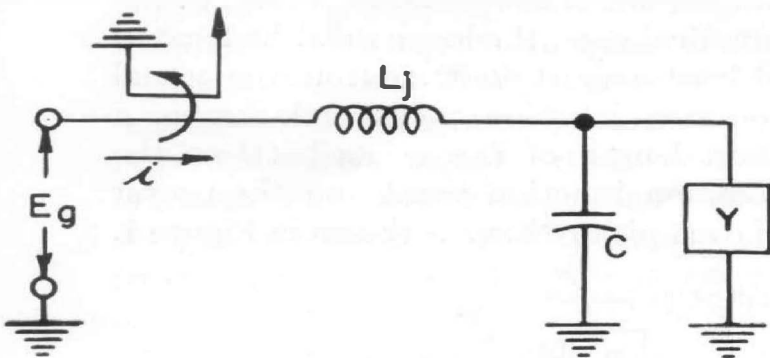

Figure 5d. Equivalent circuit showing the location of the compensating capacitance.

The approximate equivalent circuit of this arrangement is shown in Figure 5a. The series inductance of the line between the actual junction and the center of each loop is L_j . The total capacitance of the section of line is C_j . In a π equivalent of the very short section of line, half of this capacitance can be placed at either end of the series inductance. The capacitance appearing directly across the voltage source has no effect on the accuracy and, hence, can be neglected.

The current flowing through the capacitance on the load side of the junction line does not induce a voltage directly into the loop since it does not flow in the line under the loop. This current does, however, produce a voltage drop when it flows through the junction inductance and, hence, has an effect on the voltage applied to the unknown circuit. In the actual instrument, the capacitive reactance is so large compared to the inductive reactance that the voltage drop caused by the capacitive current can be neglected and, hence, C_j can be eliminated from the circuit.

The current flowing to the unknown circuit passes through the junction inductance and causes a voltage drop which can have an appreciable effect on the measurements when the measured admittance is large compared to 20 millimhos.

Since the pickup loop responds only to the current flowing in the line under the loop, the junction inductance can be shifted to the unknown side of the coupling loop without affecting the performance as shown in Figure 5c.

The same junction inductance appears in each branch, and, hence, when the unknown impedance is equal to the characteristic impedance of the line, its effects cancel. The magnitude of the effect of the inductance increases with frequency and with the magnitude of the unknown admittance. This junction inductance is minimized by bringing the outer conductor as close as is practicable to the inner conductor as shown in Figure 7. The junction inductance under these conditions is approximately 1.2 millimicrohenries. Correction can be made for its effect on the measurements, and correction charts for the older TYPE 1602-A Admittance Meters are contained in the instruction book.

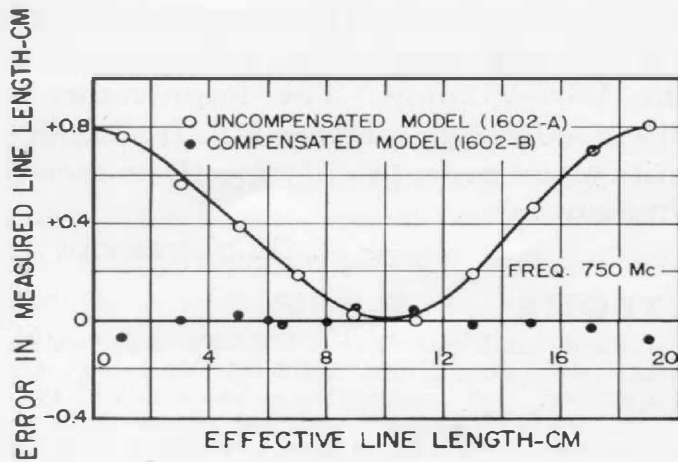

Figure 6. Curves showing the error in measured length of a short-circuited line as a function of its electrical length when the junction inductance is ignored, as measured by both the older, uncompensated Type 1602-A Admittance Meter and the new Type 1602-B compensated model.

The errors caused by ignoring the junction inductance in determinations of electrical line length from admittance measurements with the line short-circuited are shown in Figure 6. As previously mentioned, corrections can be made for this effect, but its elimination would be preferable. The effect can be eliminated by adding a shunt capacitance of the proper value to form, with the inductance, a short section of artificial transmission line, having the same characteristic impedance as the true line. For reactances small compared to the characteristic impedance, the inductance and capacitance are related by the equation:

$$Z_o = \sqrt{\frac{L}{C}}$$

The capacitance must be added on the unknown side of the coupling loop so the capacitive current will flow through the line under the loop.

In the new model, the desired additional capacitance is obtained by adding a polystyrene bead to the line, as shown in Figure 7. The electrical length of line between the unknown and the measur-

ing point is increased by about 0.7 cm. as a result but, since the corrections or adjustments are always made for the over-all length of 50-ohm line when the actual impedance or admittance is desired, the increase does not complicate the situation, but does eliminate a time-consuming correction. Besides the simplification in correction procedure obtained when admittance is measured, the VSWR is now unaffected by the junction inductance as VSWR is independent of line length and, hence, a greater accuracy is obtained.

The compensation is independent of frequency as long as the length of line added is short compared to a wavelength. Figure 6 shows the results of measurements of electrical line lengths with a compensated instrument.

Improvements to Multiplying Factor Scale

Another improvement that has been made in the Admittance Meter is the addition of several calibrated points on the multiplying-factor scale as shown in Figure 1. The additional points make greater accuracy possible in many cases by permitting the use of a lower multiplier setting.

A New Low-Frequency Susceptance Standard

A new susceptance standard has been designed for use at the lower frequencies to replace the long adjustable stub. The new standard is a small, shielded, variable air capacitor, shown in Figure 1,

Figure 7. Sketch of modified junction showing the location of one of the compensating capacitances.

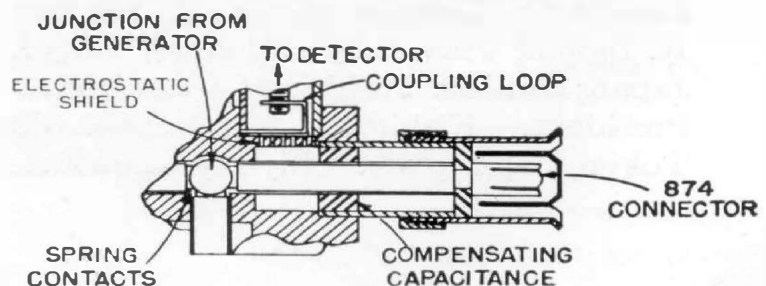



which is calibrated directly in frequency from 41 to 150 Mc. Measurements at low frequencies will be facilitated by the extended frequency range and small size of the new standard.

The Admittance Meter has earned a deserved reputation for speed, conven-

ience, and accuracy in measurements of VSWR impedance and admittance in the U-H-F range. The improvements discussed above increase still further its utility and acceptability for these measurements.

— R. A. SODERMAN

SPECIFICATIONS

Range: Theoretically, zero to infinity; practically, the lower limit is determined by the smallest readable increment on the scale which is 100 micromhos (0.1 millimho). The upper limit is 1000 millimhos. Range is the same for both conductance and susceptance, but susceptance can be either positive or negative, i.e., the susceptance dial is calibrated from -20 to +20 millimhos. Multiplying factors from 1 to 20 are provided, and factors from 20 to 100 can be determined approximately.

Frequency Range: 41 to 1000 Mc, direct reading. Range can be extended downward to 20 Mc, if a frequency correction is applied to the susceptance reading, and upward to about 1500 Mc.

Accuracy: For both conductance and susceptance (up to 1000 Mc):

From 0 to 20 millimhos ±(3% + 0.2 millimho)

From 20 to ∞ millimhos ±(3√M% + 0.2 millimho) where M is the scale multiplying factor.

Above 1000 Mc, errors increase slightly and, at 1500 Mc, the basic figure of 3% in the expression above becomes 5%. For comparing impedances, the accuracy is ±3% up to 2000 Mc.

Accessories Supplied: One TYPE 1602-P4 50-Ω Termination, for use as conductance

standard, and one TYPE 1602-P1 Adjustable Stub and one TYPE 1602-P3 Variable Air Capacitor, for susceptance standards; two TYPE 874-R20 Patch Cords for connections to generator and detector; and one TYPE 874-PB Panel Connector for installation on detector. A wooden storage case is furnished.

Additional Accessories Required: Generator and detector. Generator should cover desired frequency range and deliver between 1 volt and 10 volts. TYPE 1208-A (65 to 500 Mc), TYPE 1215-A (50 to 250 Mc), and TYPE 1209-A (250 to 920 Mc) Unit Oscillators are recommended. The TYPE 1021-AU and AV Standard-Signal Generators are also satisfactory.

Detector sensitivity should be better than 10 microvolts. Recommended detector is a heterodyne system consisting of the TYPE 874-MR Mixer Rectifier with a low-frequency receiver or an i-f amplifier and a second unit oscillator to provide the heterodyning signal.

Other Accessories Available: TYPE 874-Q Coaxial Adaptors, TYPE 874-LK Constant Impedance Adjustable Line, TYPE 874-UB Balun, TYPE 874-M Component Mount.

Terminals: All terminals are TYPE 874 Coaxial Connectors. Adaptors are available for other coaxial systems.

Dimensions: 7½ x 5½ x 5½ inches, without standards and unknown connected.

Net Weight: 8¼ pounds.

Type		Code Word	Price
1602-B	U-H-F Admittance Meter.....	HONEY	\$295.00

U. S. Patent Nos. 2,125,816 and 2,548,457.

MISCELLANY

RECENT VISITORS FROM OVERSEAS to our plant and laboratories — Mr. Virgilio Floriani, President and Technical Director, Telettra, Milan, Italy; Dr. Fred Bahli, University of Rangoon, Rangoon, Burma; Professor K. Iigima, University of Tokyo, Tokyo, Japan; and Mr. Yoshinori Chatani, Vice-President, Kishimoto Shoten, Ltd., Tokyo, Japan; Mr. Chiyo Yamonaka,

Department of Electrical Engineering, Osaka University, Osaka, Japan.

PAPERS — “A Balanced Crystal-Diode Modulator for UHF,” by William F. Byers, Engineer, at the 1953 National Conference on Airborne Electronics, Dayton, Ohio, May 12, 1953. No copies of this paper are as yet available, but an abstract appears in the *Conference Proceedings*.



MEASUREMENTS ON 75 OHM LINES WITH THE ADMITTANCE METER

In many television receiving systems, 72- or 75-ohm transmission lines are used. The impedance or VSWR of the line can be easily measured, using either the old or new model of the Admittance Meter. Means must be devised, however, for connecting the 75-ohm line to the Admittance Meter, which is equipped with 50-ohm connectors. One solution to this problem is to fit the 75-ohm line with a General Radio TYPE 874 Connector. TYPE 874-C8 Cable Connectors are suitable for use with RG 11/U Cable and TYPE 874-C62 Cable Connectors are suitable for use with RG 59/U Cable. The TYPE 874 Connectors are 50-ohm connectors, and the junction between the 50-ohm line and 75-ohm line is made at the point indicated in Figure 1. There is a slight discontinuity at the junction due to stray reactances, but in most cases the effect is negligible.

The effect of the 50-ohm line in the connectors and the Admittance Meter can be eliminated by adjusting it to a half- or quarter-wavelength by means of a TYPE 874-LK Constant Impedance Adjustable Line. To obtain the proper half-wavelength adjustment, the 50-ohm line should be open-circuited at the 75-ohm line junction, the Admittance Meter set to balance at zero admittance, and the line length adjusted until a null is obtained. For a quarter-wavelength adjustment, the same procedure is used with the exception that the line is short-circuited at the junction. In the practical case, it is difficult to open-circuit or short-circuit the line at the proper point, but the TYPES 874-WO or WO-3 Open-Circuit Terminations and 874-WN

or WN-3 Short-Circuit Terminations can be used to advantage for this purpose. These units do not produce an open-circuit exactly at the desired point, but minor adjustments of the line length can be made to compensate for the difference.

In this application, the termination is connected to the end of the adjustable line in place of the line under test, and the line length is adjusted as outlined above. Then, if the TYPE 874-WO Open-Circuit Termination or TYPE 874-WN Short-Circuit Termination is used, the adjustable line should be decreased in length 2.6 cm, and if the TYPE 876-WO3 Open-Circuit Termination or TYPE 874-WN3 Short-Circuit Termination is used, the length of the adjustable line should be increased 0.6 cm. If the termination is removed and the line under test connected, the length of 50-ohm line between the measuring point and the point at which the 75-ohm line is connected is now exactly a half- or quarter-wavelength long. For the half-wavelength adjustment, the admittance measured by the instrument is the admittance seen looking into the 75-ohm line at the junction. For the quarter-wavelength adjustment, the unknown series resistance and reactance are equal to the indicated conductance and susceptance respectively, multiplied by 2.5.

Figure 1. Sketch of Type 874-C63 Cable Connector with a 75-ohm cable attached.

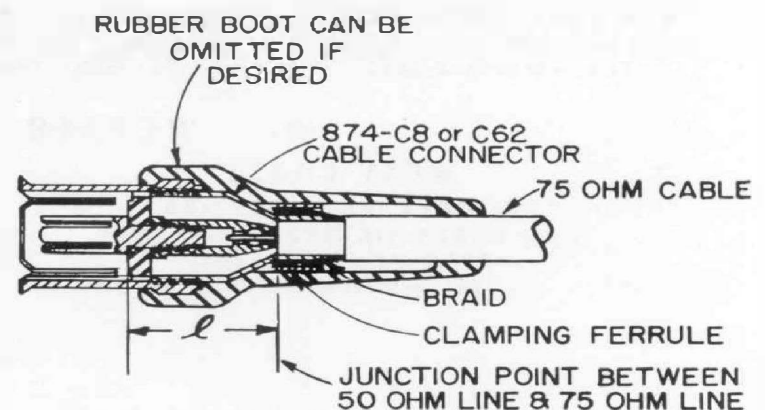



The VSWR on the 75-ohm line can be calculated from the measured admittance, using the equation or Smith chart as outlined in the instruction book. Reflection coefficient and, hence, VSWR can also be measured directly by a voltage-ratio method similar to that outlined for 50-ohm lines in the instruction book.

For this measurement, the 75-ohm line under test with its associated adjustable line should be connected to the branch line usually connected to the conductance standard. The branch line usually connected to the unknown should be open-circuited and the multiplier set at infinity. These connections are the reverse of those used when measuring 50-ohm lines and are necessary because the coupling to the unknown must be adjusted to be a specific value less than unity to compensate for the difference in characteristic impedance, and the conductance coupling is more finely calibrated than is the multiplier coupling and hence can be set more accurately.

The over-all 50-ohm line length should then be adjusted to be a quarter-wavelength, using the method previously described with the exception that the conductance indicator is set to maximum coupling, or 20, and the multiplier left at infinity. The susceptance standard is then removed and replaced by the conductance standard, the conductance

indicator set at $20 \times \frac{50}{Z_0}$, where Z_0 is the characteristic impedance of the line under test.^{3,4} The ratio of the detector voltages obtained with the susceptance indicator first set to -20 and then to +20 is equal to the reflection coefficient Γ on the 75-ohm line, and

$$VSWR_{75} = \frac{1 + \Gamma}{1 - \Gamma}$$

— R. A. SODERMAN

³This method was suggested by Mr. B. Parzen of Federal Telecommunication Laboratories.

⁴This method can be used for any line having a characteristic impedance greater than 50 ohms. For lines having characteristic impedances less than 50 ohms, the same method can be used with the length of 50-ohm line set at a half-wavelength, and the conductance indicator set at $20 \times \frac{Z_0}{50}$.

Type		Code Word	Price
874-C62	Connector for RG62/U Cable.....	COAXCANDOR	\$1.70

GENERAL RADIO COMPANY

275 MASSACHUSETTS AVENUE

CAMBRIDGE 39

MASSACHUSETTS

TELEPHONE: TRowbridge 6-4400

BRANCH ENGINEERING OFFICES

NEW YORK 6, NEW YORK
90 WEST STREET
TEL.—WOrth 2-5837

LOS ANGELES 38, CALIFORNIA
1000 NORTH SEWARD STREET
TEL.—HOLlywood 9-6201

CHICAGO 5, ILLINOIS
920 SOUTH MICHIGAN AVENUE
TEL.—WABash 2-3820

REPAIR SERVICES

WEST COAST

WESTERN INSTRUMENT CO.
826 NORTH VICTORY BOULEVARD
BURBANK, CALIFORNIA
TEL.—ROckwell 9-3013

CANADA

BAYLY ENGINEERING, LTD.
5 FIRST STREET
AJAX, ONTARIO
TEL.—Toronto WA-6866